

## UNIT- V SYMBOL TABLES AND CODE GENERATION

### Representing Information in Symbol Table

**Symbol Table** is an important data structure created and maintained by the compiler in order to keep track of semantics of variable i.e. it stores information about scope and binding information about names, information about instances of various entities such as variable and function names, classes, objects, etc.

- It is built in lexical and syntax analysis phases.
- The information is collected by the analysis phases of compiler and is used by synthesis phases of compiler to generate code.
- It is used by compiler to achieve compile time efficiency.
- It is used by various phases of compiler as follows :-
  1. **Lexical Analysis:** Creates new table entries in the table, example like entries about token.
  2. **Syntax Analysis:** Adds information regarding attribute type, scope, dimension, line of reference, use, etc in the table.
  3. **Semantic Analysis:** Uses available information in the table to check for semantics i.e. to verify that expressions and assignments are semantically correct(type checking) and update it accordingly.
  4. **Intermediate Code generation:** Refers symbol table for knowing how much and what type of run-time is allocated and table helps in adding temporary variable information.
  5. **Code Optimization:** Uses information present in symbol table for machine dependent optimization.
  6. **Target Code generation:** Generates code by using address information of identifier present in the table.

**Symbol Table entries** – Each entry in symbol table is associated with attributes that support compiler in different phases.

#### Items stored in Symbol table:

- Variable names and constants
- Procedure and function names
- Literal constants and strings
- Compiler generated temporaries
- Labels in source languages

#### Information used by compiler from Symbol table:

- Data type and name
- Declaring procedures
- Offset in storage
- If structure or record then, pointer to structure table.
- For parameters, whether parameter passing by value or by reference
- Number and type of arguments passed to function

- Base Address

**Operations of Symbol table** – The basic operations defined on a symbol table include:

Operation	Function
allocate	to allocate a new empty symbol table
free	to remove all entries and free storage of symbol table
lookup	to search for a name and return pointer to its entry
insert	to insert a name in a symbol table and return a pointer to its entry
set_attribute	to associate an attribute with a given entry
get_attribute	to get an attribute associated with a given entry

### Implementation of Symbol table

Following are commonly used data structure for implementing symbol table :-

#### 1. List

- In this method, an array is used to store names and associated information.
- A pointer “**available**” is maintained at end of all stored records and new names are added in the order as they arrive
- To search for a name we start from beginning of list till available pointer and if not found we get an error “**use of undeclared name**”
- While inserting a new name we must ensure that it is not already present otherwise error occurs i.e. “**Multiple defined name**”
- Insertion is fast  $O(1)$ , but lookup is slow for large tables –  $O(n)$  on average
- Advantage is that it takes minimum amount of space.

#### 2. Linked List

- This implementation is using linked list. A link field is added to each record.
- Searching of names is done in order pointed by link of link field.
- A pointer “**First**” is maintained to point to first record of symbol table.
- Insertion is fast  $O(1)$ , but lookup is slow for large tables –  $O(n)$  on average

### 3. Hash Table

- In hashing scheme two tables are maintained – a hash table and symbol table and is the most commonly used method to implement symbol tables..
- A hash table is an array with index range: 0 to tablesize – 1. These entries are pointer pointing to names of symbol table.
- To search for a name we use hash function that will result in any integer between 0 to tablesize – 1.
- Insertion and lookup can be made very fast –  $O(1)$ .
- Advantage is quick search is possible and disadvantage is that hashing is complicated to implement.

### 4. Binary Search Tree

- Another approach to implement symbol table is to use binary search tree i.e. we add two link fields i.e. left and right child.
- All names are created as child of root node that always follow the property of binary search tree.
- Insertion and lookup are  $O(\log_2 n)$  on average.

# UNIT V - Introduction to Code Optimization

## BASIC BLOCKS AND FLOW GRAPHS

### Basic Blocks

- A *basic block* is a sequence of consecutive statements in which flow of control enters at the beginning and leaves at the end without any halt or possibility of branching except at the end.
- The following sequence of three-address statements forms a basic block:  
 $t_1 := a * a$   
 $t_2 := a * b$   
 $t_3 := 2 * t_2$   
 $t_4 := t_1 + t_3$   
 $t_5 := b * b$   
 $t_6 := t_4 + t_5$

### Basic Block Construction:

**Algorithm:** Partition into basic blocks

**Input:** A sequence of three-address statements

**Output:** A list of basic blocks with each three-address statement in exactly one block

**Method:**

1. We first determine the set of *leaders*, the first statements of basic blocks. The rules we use are of the following:
  - a. The first statement is a leader.
  - b. Any statement that is the target of a conditional or unconditional goto is a leader.
  - c. Any statement that immediately follows a goto or conditional goto statement is a leader.
2. For each leader, its basic block consists of the leader and all statements up to but not including the next leader or the end of the program.

- Consider the following source code for dot product of two vectors a and b of length 20

```
begin
    prod :=0;
    i:=1;
    do begin
        prod :=prod+ a[i] * b[i];
        i :=i+1;
    end
    while i <= 20
end
```

- The three-address code for the above source program is given as :

```
(1)   prod := 0
(2)   i := 1
(3)   t1 := 4* i
(4)   t2 := a[t1]    /*compute a[i] */
(5)   t3 := 4* i
(6)   t4 := b[t3]    /*compute b[i] */
(7)   t5 := t2*t4
(8)   t6 := prod+t5
(9)   prod := t6
(10)  t7 := i+1
(11)  i := t7
(12)  if i<=20 goto (3)
```

Basic block 1: Statement (1) to (2)

Basic block 2: Statement (3) to (12)

## Transformations on Basic Blocks:

A number of transformations can be applied to a basic block without changing the set of expressions computed by the block. Two important classes of transformation are :

- Structure-preserving transformations
- Algebraic transformations

### 1. Structure preserving transformations:

#### a) Common subexpression elimination:

$a := b + c$		$a := b + c$
$b := a - d$	$\longrightarrow$	$b := a - d$
$c := b + c$		$c := b + c$
$d := a - d$		$d := b$

Since the second and fourth expressions compute the same expression, the basic block can be transformed as above.

#### b) Dead-code elimination:

Suppose  $x$  is dead, that is, never subsequently used, at the point where the statement  $x := y + z$  appears in a basic block. Then this statement may be safely removed without changing the value of the basic block.

#### c) Renaming temporary variables:

A statement  $t := b + c$  ( $t$  is a temporary) can be changed to  $u := b + c$  ( $u$  is a new temporary) and all uses of this instance of  $t$  can be changed to  $u$  without changing the value of the basic block.

Such a block is called a *normal-form block*.

#### d) Interchange of statements:

Suppose a block has the following two adjacent statements:

$t_1 := b + c$
$t_2 := x + y$

We can interchange the two statements without affecting the value of the block if and only if neither  $x$  nor  $y$  is  $t_1$  and neither  $b$  nor  $c$  is  $t_2$ .

### 2. Algebraic transformations:

Algebraic transformations can be used to change the set of expressions computed by a basic block into an algebraically equivalent set.

Examples:

- $x := x + 0$  or  $x := x * 1$  can be eliminated from a basic block without changing the set of expressions it computes.
- The exponential statement  $x := y * * 2$  can be replaced by  $x := y * y$ .

## Flow Graphs

- Flow graph is a directed graph containing the flow-of-control information for the set of basic blocks making up a program.
- The nodes of the flow graph are basic blocks. It has a distinguished initial node.
- E.g.: Flow graph for the vector dot product is given as follows:

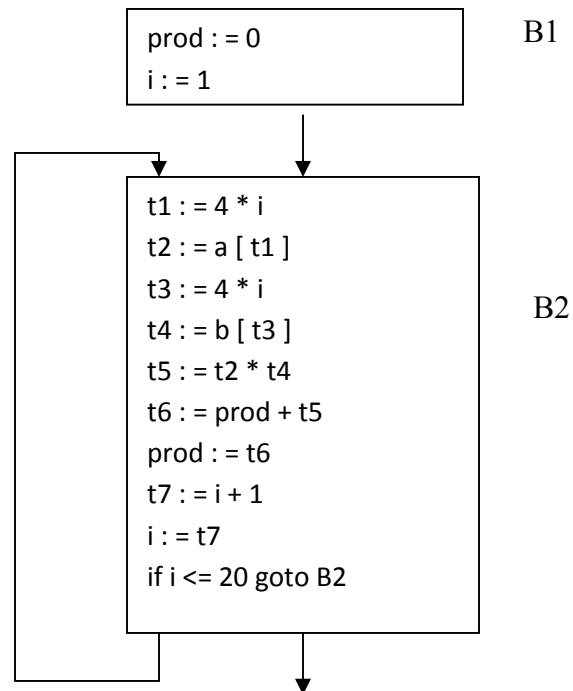

- $B_1$  is the *initial* node.  $B_2$  immediately follows  $B_1$ , so there is an edge from  $B_1$  to  $B_2$ . The target of jump from last statement of  $B_1$  is the first statement  $B_2$ , so there is an edge from  $B_1$  (last statement) to  $B_2$  (first statement).
- $B_1$  is the *predecessor* of  $B_2$ , and  $B_2$  is a *successor* of  $B_1$ .

## Loops

- A loop is a collection of nodes in a flow graph such that
  1. All nodes in the collection are *strongly connected*.
  2. The collection of nodes has a unique *entry*.
- A loop that contains no other loops is called an inner loop.

## **NEXT-USE INFORMATION**

- If the name in a register is no longer needed, then we remove the name from the register and the register can be used to store some other names.

**Input:** Basic block B of three-address statements

**Output:** At each statement  $i: x = y \text{ op } z$ , we attach to  $i$  the liveness and next-uses of  $x$ ,  $y$  and  $z$ .

**Method:** We start at the last statement of B and scan backwards.

1. Attach to statement  $i$  the information currently found in the symbol table regarding the next-use and liveness of  $x$ ,  $y$  and  $z$ .
2. In the symbol table, set  $x$  to “not live” and “no next use”.
3. In the symbol table, set  $y$  and  $z$  to “live”, and next-uses of  $y$  and  $z$  to  $i$ .

### Symbol Table:

Names	Liveness	Next-use
x	not live	no next-use
y	Live	i
z	Live	i

### A SIMPLE CODE GENERATOR

- A code generator generates target code for a sequence of three-address statements and effectively uses registers to store operands of the statements.
- For example: consider the three-address statement  $a := b+c$   
It can have the following sequence of codes:

ADD  $R_j, R_i$                       Cost = 1    // if  $R_i$  contains  $b$  and  $R_j$  contains  $c$

(or)

ADD  $c, R_i$                           Cost = 2    // if  $c$  is in a memory location

(or)

MOV  $c, R_j$                         Cost = 3    // move  $c$  from memory to  $R_j$  and add

ADD  $R_j, R_i$

### Register and Address Descriptors:

- A register descriptor is used to keep track of what is currently in each registers. The register descriptors show that initially all the registers are empty.
- An address descriptor stores the location where the current value of the name can be found at run time.

### A code-generation algorithm:

The algorithm takes as input a sequence of three-address statements constituting a basic block. For each three-address statement of the form  $x := y \text{ op } z$ , perform the following actions:

1. Invoke a function *getreg* to determine the location  $L$  where the result of the computation  $y \text{ op } z$  should be stored.
2. Consult the address descriptor for  $y$  to determine  $y'$ , the current location of  $y$ . Prefer the register for  $y'$  if the value of  $y$  is currently both in memory and a register. If the value of  $y$  is not already in  $L$ , generate the instruction **MOV  $y'$ ,  $L$**  to place a copy of  $y$  in  $L$ .
3. Generate the instruction **OP  $z'$ ,  $L$**  where  $z'$  is a current location of  $z$ . Prefer a register to a memory location if  $z$  is in both. Update the address descriptor of  $x$  to indicate that  $x$  is in location  $L$ . If  $x$  is in  $L$ , update its descriptor and remove  $x$  from all other descriptors.
4. If the current values of  $y$  or  $z$  have no next uses, are not live on exit from the block, and are in registers, alter the register descriptor to indicate that, after execution of  $x := y \text{ op } z$ , those registers will no longer contain  $y$  or  $z$ .

### Generating Code for Assignment Statements:

- The assignment  $d := (a-b) + (a-c) + (a-c)$  might be translated into the following three-address code sequence:

$t := a - b$

$u := a - c$

$v := t + u$

$d := v + u$

with  $d$  live at the end.

Code sequence for the example is:

Statements	Code Generated	Register descriptor	Address descriptor
		Register empty	
$t := a - b$	MOV a, R0 SUB b, R0	R0 contains t	t in R0
$u := a - c$	MOV a, R1 SUB c, R1	R0 contains t R1 contains u	t in R0 u in R1
$v := t + u$	ADD R1, R0	R0 contains v R1 contains u	u in R1 v in R0
$d := v + u$	ADD R1, R0  MOV R0, d	R0 contains d	d in R0 d in R0 and memory

## Generating Code for Indexed Assignments

The table shows the code sequences generated for the indexed assignment statements

$a := b[i]$  and  $a[i] := b$

Statements	Code Generated	Cost
$a := b[i]$	MOV b(R <sub>i</sub> ), R	2
$a[i] := b$	MOV b, a(R <sub>i</sub> )	3

## Generating Code for Pointer Assignments

The table shows the code sequences generated for the pointer assignments

$a := *p$  and  $*p := a$

Statements	Code Generated	Cost
$a := *p$	MOV *R <sub>p</sub> , a	2
$*p := a$	MOV a, *R <sub>p</sub>	2

## Generating Code for Conditional Statements

Statement	Code
if $x < y$ goto z	CMP x, y CJ< z /* jump to z if condition code is negative */
$x := y + z$ if $x < 0$ goto z	MOV y, R <sub>0</sub> ADD z, R <sub>0</sub> MOV R <sub>0</sub> , x CJ< z

## THE DAG REPRESENTATION FOR BASIC BLOCKS

- A DAG for a basic block is a **directed acyclic graph** with the following labels on nodes:
  1. Leaves are labeled by unique identifiers, either variable names or constants.
  2. Interior nodes are labeled by an operator symbol.
  3. Nodes are also optionally given a sequence of identifiers for labels to store the computed values.
- DAGs are useful data structures for implementing transformations on basic blocks.
- It gives a picture of how the value computed by a statement is used in subsequent statements.
- It provides a good way of determining common sub - expressions.

## Algorithm for construction of DAG

**Input:** A basic block

**Output:** A DAG for the basic block containing the following information:

1. A label for each node. For leaves, the label is an identifier. For interior nodes, an operator symbol.
2. For each node a list of attached identifiers to hold the computed values.

Case (i)  $x := y \text{ OP } z$

Case (ii)  $x := \text{OP } y$

Case (iii)  $x := y$

**Method:**

**Step 1:** If  $y$  is undefined then create node( $y$ ).

If  $z$  is undefined, create node( $z$ ) for case(i).

**Step 2:** For the case(i), create a node(OP) whose left child is node( $y$ ) and right child is

node( $z$ ). ( Checking for common sub expression). Let  $n$  be this node.

For case(ii), determine whether there is node(OP) with one child node( $y$ ). If not create such a node.

For case(iii), node  $n$  will be node( $y$ ).

**Step 3:** Delete  $x$  from the list of identifiers for node( $x$ ). Append  $x$  to the list of attached

identifiers for the node  $n$  found in step 2 and set node( $x$ ) to  $n$ .

**Example:** Consider the block of three- address statements:

1.  $t_1 := 4 * i$
2.  $t_2 := a[t_1]$
3.  $t_3 := 4 * i$
4.  $t_4 := b[t_3]$
5.  $t_5 := t_2 * t_4$
6.  $t_6 := \text{prod} + t_5$
7.  $\text{prod} := t_6$
8.  $t_7 := i + 1$
9.  $i := t_7$
10. if  $i \leq 20$  goto (1)

## Stages in DAG Construction

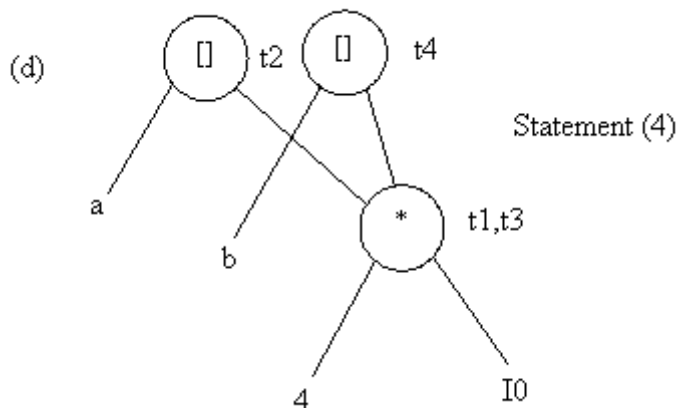
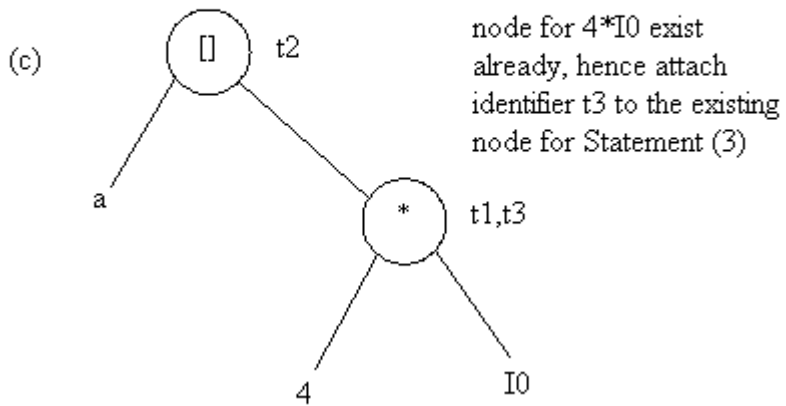
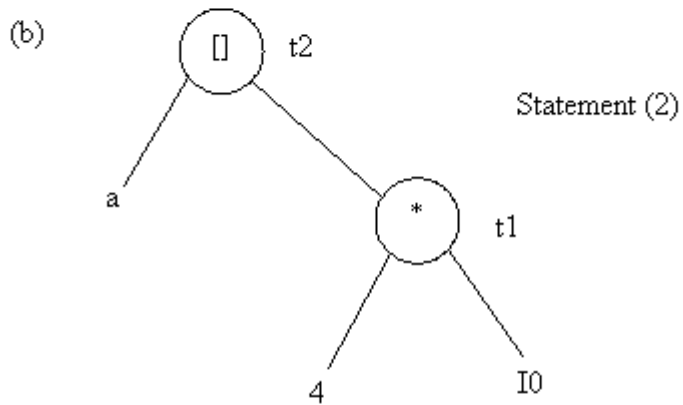
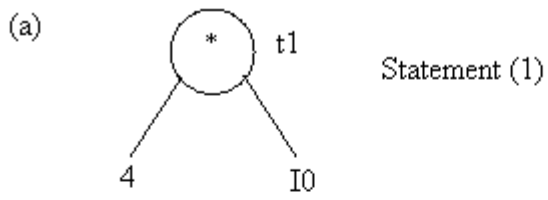

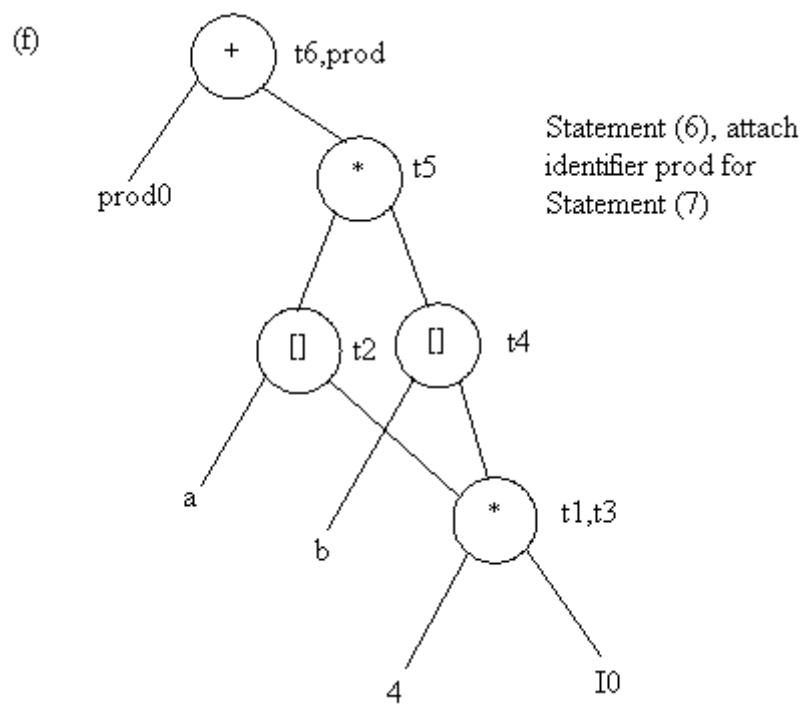
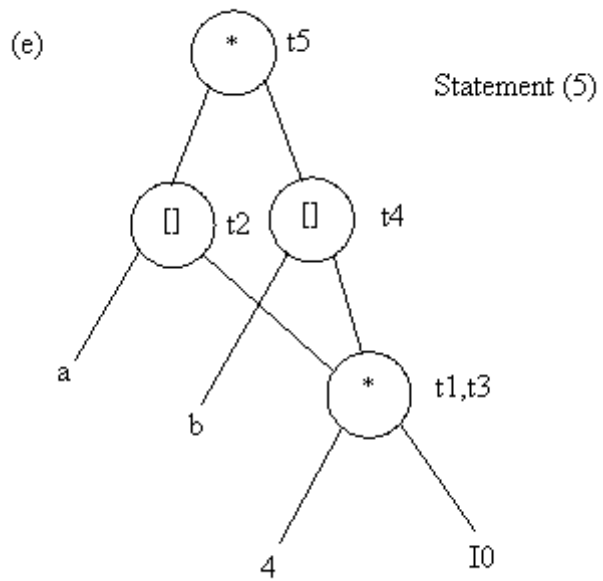

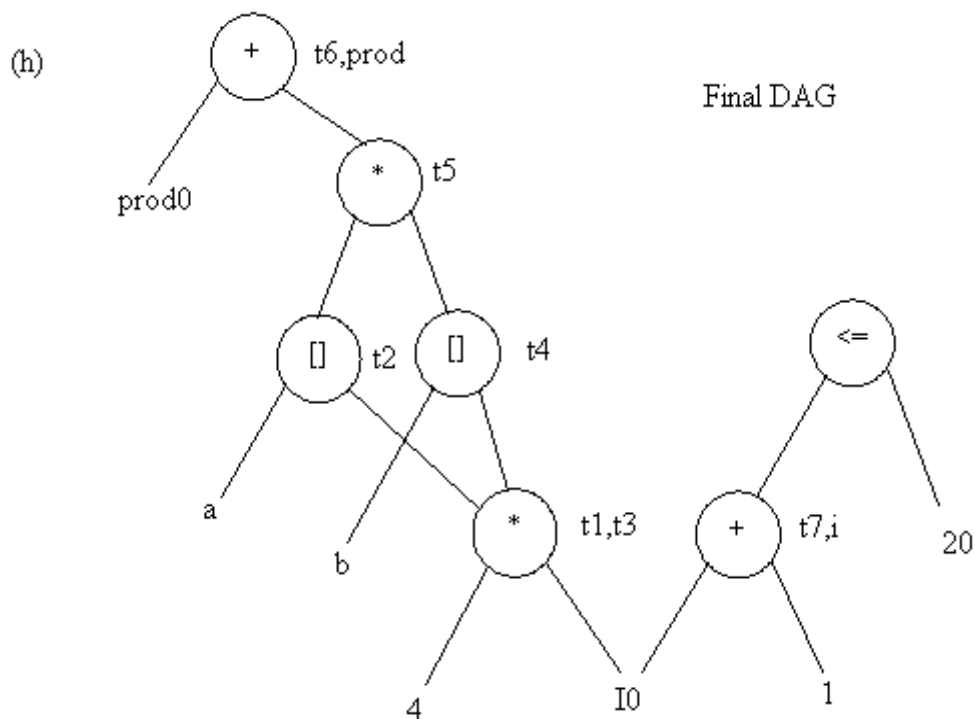
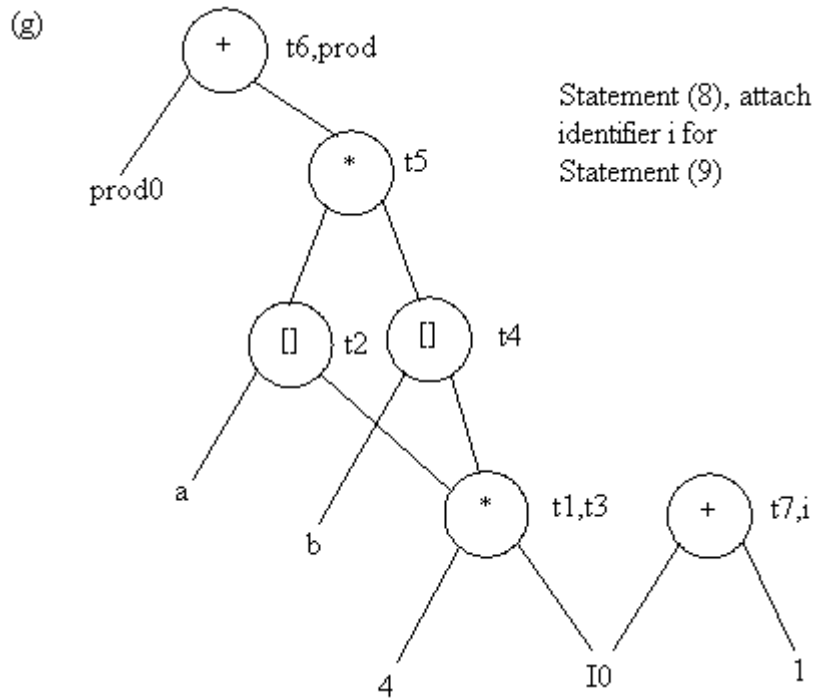

**Application of DAGs:**

1. We can automatically detect common sub expressions.
2. We can determine which identifiers have their values used in the block.
3. We can determine which statements compute values that could be used outside the block.

## GENERATING CODE FROM DAGs

The advantage of generating code for a basic block from its dag representation is that, from a dag we can easily see how to rearrange the order of the final computation sequence than we can starting from a linear sequence of three-address statements or quadruples.

### Rearranging the order

The order in which computations are done can affect the cost of resulting object code.

For example, consider the following basic block:

```
t1 := a + b
t2 := c + d
t3 := e - t2
t4 := t1 - t3
```

### **Generated code sequence for basic block:**

```
MOV a , R0
ADD b , R0
MOV c , R1
ADD d , R1
MOV R0 , t1
MOV e , R0
SUB R1 , R0
MOV t1 , R1
SUB R0 , R1
MOV R1 , t4
```

### **Rearranged basic block:**

Now t<sub>1</sub> occurs immediately before t<sub>4</sub>.

```
t2 := c + d
t3 := e - t2
t1 := a + b
t4 := t1 - t3
```

### **Revised code sequence:**

```
MOV c , R0
ADD d , R0
MOV a , R0
SUB R0 , R1
MOV a , R0
ADD b , R0
SUB R1 , R0
MOV R0 , t4
```

In this order, two instructions **MOV R<sub>0</sub> , t<sub>1</sub>** and **MOV t<sub>1</sub> , R<sub>1</sub>** have been saved.

## A Heuristic ordering for Dags

The heuristic ordering algorithm attempts to make the evaluation of a node immediately follow the evaluation of its leftmost argument.

The algorithm shown below produces the ordering in reverse.

### Algorithm:

- 1) **while** unlisted interior nodes remain **do begin**
- 2)     select an unlisted node  $n$ , all of whose parents have been listed;
- 3)     list  $n$ ;
- 4)     **while** the leftmost child  $m$  of  $n$  has no unlisted parents and is not a leaf **do**  
       **begin**
- 5)         list  $m$ ;
- 6)          $n := m$
- end**
- end**

**Example:** Consider the DAG shown below:

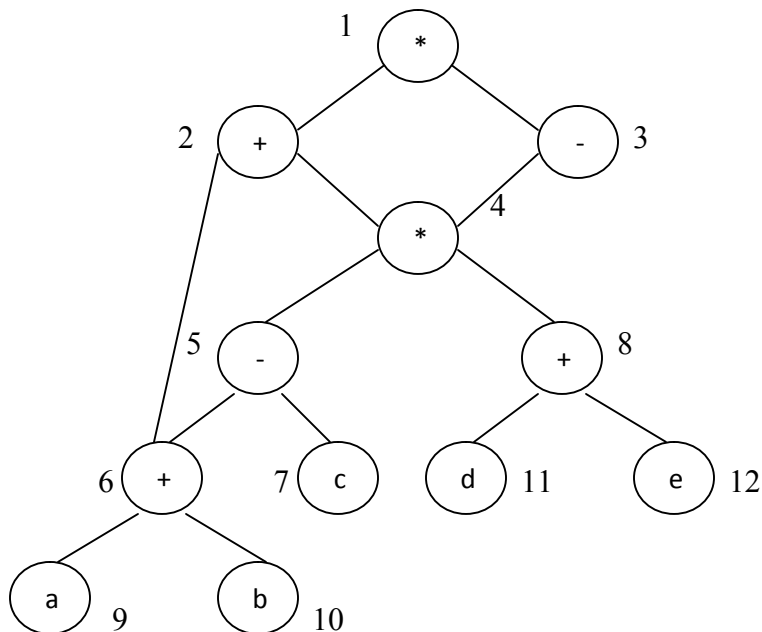

Initially, the only node with no unlisted parents is 1 so set  $n=1$  at line (2) and list 1 at line (3).

Now, the left argument of 1, which is 2, has its parents listed, so we list 2 and set  $n=2$  at line (6).

Now, at line (4) we find the leftmost child of 2, which is 6, has an unlisted parent 5. Thus we select a new  $n$  at line (2), and node 3 is the only candidate. We list 3 and proceed down its left chain, listing 4, 5 and 6. This leaves only 8 among the interior nodes so we list that.

The resulting list is 1234568 and the order of evaluation is 8654321.

**Code sequence:** $t_8 := d + e$  $t_6 := a + b$  $t_5 := t_6 - c$  $t_4 := t_5 * t_8$  $t_3 := t_4 - e$  $t_2 := t_6 + t_4$  $t_1 := t_2 * t_3$ 

This will yield an optimal code for the DAG on machine whatever be the number of registers.

## UNIT V - CODE OPTIMIZATION & CODE GENERATION

The final phase in compiler model is the code generator. It takes as input an intermediate representation of the source program and produces as output an equivalent target program. The code generation techniques presented below can be used whether or not an optimizing phase occurs before code generation.

### Position of code generator

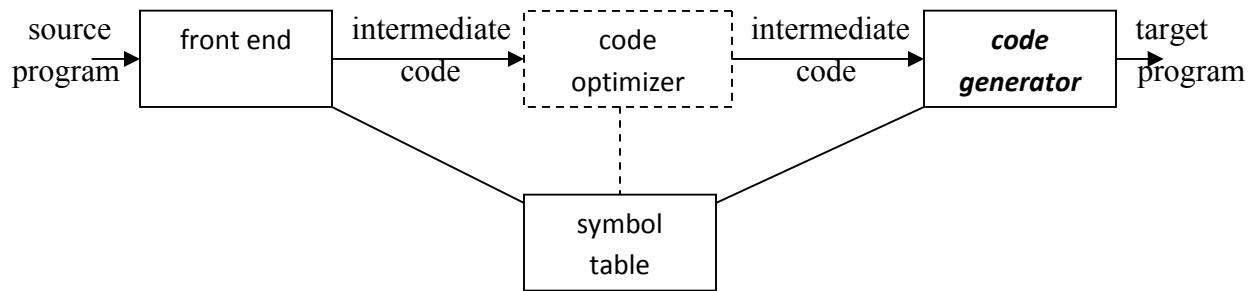

### ISSUES IN THE DESIGN OF A CODE GENERATOR

The following issues arise during the code generation phase :

1. Input to code generator
2. Target program
3. Memory management
4. Instruction selection
5. Register allocation
6. Evaluation order

#### 1. Input to code generator:

- The input to the code generation consists of the intermediate representation of the source program produced by front end , together with information in the symbol table to determine run-time addresses of the data objects denoted by the names in the intermediate representation.
- Intermediate representation can be :
  - a. Linear representation such as postfix notation
  - b. Three address representation such as quadruples
  - c. Virtual machine representation such as stack machine code
  - d. Graphical representations such as syntax trees and dags.
- Prior to code generation, the front end must be scanned, parsed and translated into intermediate representation along with necessary type checking. Therefore, input to code generation is assumed to be error-free.

#### 2. Target program:

- The output of the code generator is the target program. The output may be :
  - a. Absolute machine language
    - It can be placed in a fixed memory location and can be executed immediately.

- b. Relocatable machine language
  - It allows subprograms to be compiled separately.
- c. Assembly language
  - Code generation is made easier.

### 3. Memory management:

- Names in the source program are mapped to addresses of data objects in run-time memory by the front end and code generator.
- It makes use of symbol table, that is, a name in a three-address statement refers to a symbol-table entry for the name.
- Labels in three-address statements have to be converted to addresses of instructions. For example,
  - $j$ : **goto**  $i$  generates jump instruction as follows :
    - if  $i < j$ , a backward jump instruction with target address equal to location of code for quadruple  $i$  is generated.
    - if  $i > j$ , the jump is forward. We must store on a list for quadruple  $i$  the location of the first machine instruction generated for quadruple  $j$ . When  $i$  is processed, the machine locations for all instructions that forward jumps to  $i$  are filled.

### 4. Instruction selection:

- The instructions of target machine should be complete and uniform.
- Instruction speeds and machine idioms are important factors when efficiency of target program is considered.
- The quality of the generated code is determined by its speed and size.
- The former statement can be translated into the latter statement as shown below:

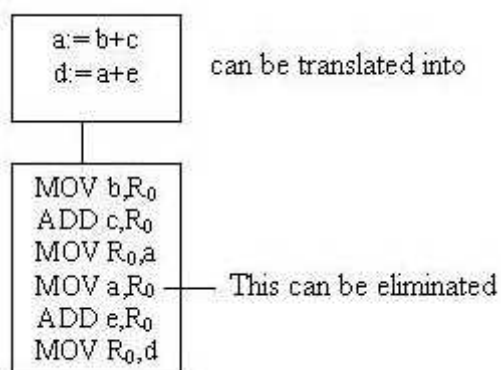

### 5. Register allocation

- Instructions involving register operands are shorter and faster than those involving operands in memory.
- The use of registers is subdivided into two subproblems :
  - **Register allocation** – the set of variables that will reside in registers at a point in the program is selected.

➤ **Register assignment** – the specific register that a variable will reside in is picked.

- Certain machine requires even-odd *register pairs* for some operands and results. For example, consider the division instruction of the form :

D  $x, y$

where,  $x$  – dividend even register in even/odd register pair

$y$  – divisor

even register holds the remainder

odd register holds the quotient

## 6. Evaluation order

- The order in which the computations are performed can affect the efficiency of the target code. Some computation orders require fewer registers to hold intermediate results than others.

## TARGET MACHINE

- Familiarity with the target machine and its instruction set is a prerequisite for designing a good code generator.
- The target computer is a byte-addressable machine with 4 bytes to a word.
- It has  $n$  general-purpose registers,  $R_0, R_1, \dots, R_{n-1}$ .
- It has two-address instructions of the form:  
 $op \ source, destination$   
 where,  $op$  is an op-code, and  $source$  and  $destination$  are data fields.
- It has the following op-codes :  
 MOV (move  $source$  to  $destination$ )  
 ADD (add  $source$  to  $destination$ )  
 SUB (subtract  $source$  from  $destination$ )
- The  $source$  and  $destination$  of an instruction are specified by combining registers and memory locations with address modes.

### Address modes with their assembly-language forms

MODE	FORM	ADDRESS	ADDED COST
<i>absolute</i>	M	M	1
<i>register</i>	R	R	0
<i>indexed</i>	$c(R)$	$c + contents(R)$	1
<i>indirect register</i>	*R	$contents(R)$	0
<i>indirect indexed</i>	* $c(R)$	$contents(c + contents(R))$	1
<i>literal</i>	# $c$	$c$	1

- For example : `MOV R0, M` stores contents of Register R<sub>0</sub> into memory location M ;  
`MOV 4(R0), M` stores the value *contents(4+contents(R<sub>0</sub>))* into M.

### Instruction costs :

- Instruction cost = 1+cost for source and destination address modes. This cost corresponds to the length of the instruction.
- Address modes involving registers have cost zero.
- Address modes involving memory location or literal have cost one.
- Instruction length should be minimized if space is important. Doing so also minimizes the time taken to fetch and perform the instruction.

For example : `MOV R0, R1` copies the contents of register R0 into R1. It has cost one, since it occupies only one word of memory.

- The three-address statement `a := b + c` can be implemented by many different instruction sequences :

i) `MOV b, R0`

`ADD c, R0`                      cost = 6

`MOV R0, a`

ii) `MOV b, a`

`ADD c, a`                              cost = 6

iii) Assuming R<sub>0</sub>, R<sub>1</sub> and R<sub>2</sub> contain the addresses of a, b, and c :

`MOV *R1, *R0`

`ADD *R2, *R0`                      cost = 2

- In order to generate good code for target machine, we must utilize its addressing capabilities efficiently.

### RUN-TIME STORAGE MANAGEMENT

- Information needed during an execution of a procedure is kept in a block of storage called an activation record, which includes storage for names local to the procedure.
- The two standard storage allocation strategies are:
  1. Static allocation
  2. Stack allocation
- In static allocation, the position of an activation record in memory is fixed at compile time.
- In stack allocation, a new activation record is pushed onto the stack for each execution of a procedure. The record is popped when the activation ends.
- The following three-address statements are associated with the run-time allocation and deallocation of activation records:
  1. Call,
  2. Return,
  3. Halt, and
  4. Action, a placeholder for other statements.
- We assume that the run-time memory is divided into areas for:
  1. Code
  2. Static data
  3. Stack

## Static allocation

### **Implementation of call statement:**

The codes needed to implement static allocation are as follows:

```
MOV #here + 20, callee.static_area      /*It saves return address*/
```

```
GOTO callee.code_area      /*It transfers control to the target code for the called procedure */
```

where,

*callee.static\_area* – Address of the activation record

*callee.code\_area* – Address of the first instruction for called procedure

*#here + 20* – Literal return address which is the address of the instruction following GOTO.

### **Implementation of return statement:**

A return from procedure *callee* is implemented by :

```
GOTO *callee.static_area
```

This transfers control to the address saved at the beginning of the activation record.

### **Implementation of action statement:**

The instruction ACTION is used to implement action statement.

### **Implementation of halt statement:**

The statement HALT is the final instruction that returns control to the operating system.

## Stack allocation

Static allocation can become stack allocation by using relative addresses for storage in activation records. In stack allocation, the position of activation record is stored in register so words in activation records can be accessed as offsets from the value in this register.

The codes needed to implement stack allocation are as follows:

### **Initialization of stack:**

```
MOV #stackstart , SP      /* initializes stack */
```

Code for the first procedure

```
HALT                    /* terminate execution */
```

### **Implementation of Call statement:**

```
ADD #caller.recordsize, SP  /* increment stack pointer */
```

```
MOV #here + 16, *SP      /*Save return address */
```

```
GOTO callee.code_area
```